



Compar linear – Powerhouse for linear aesthetics

Differentiated light from the ceiling in an innovative design

The recessed downlights with a concise and linear housing shape, available from widths of 2" (52mm), set accents in the ceiling design and simultaneously function as highly efficient lighting tools with high levels of visual comfort. The wide spectrum of distribution options for nuanced general and office lighting convinces in any high-quality architecture. Compar is an attractive alternative to lighting with conventional linear luminaires. With Compar, ceiling-integrated lighting concepts can

be realized in restaurants as well as administrative, cultural and office buildings.

Compar linear Recessed luminaires

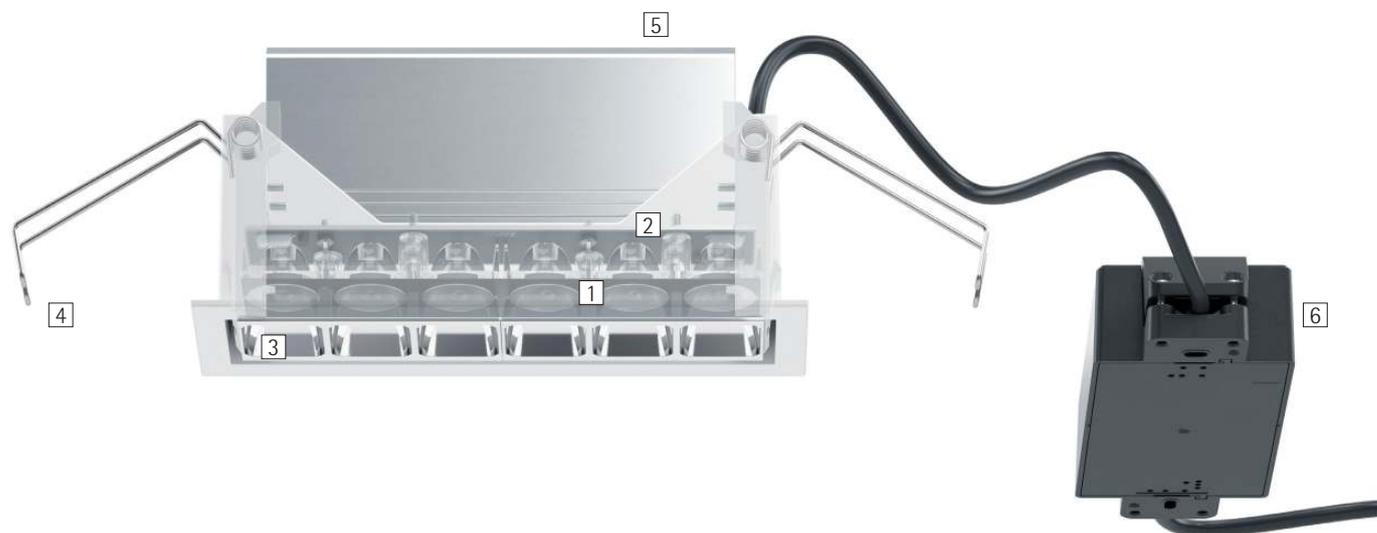

Structure and characteristics

The features described here are typical of products in this range. Special versions may offer additional or varying features. A comprehensive description of the features of individual products can be found on our website.

1 ERCO lens system

- Made of optical polymer
- Light distributions: spot, flood, wide flood, extra wide flood, oval wide flood or oval flood

or

Reflector (lens wallwasher)

- Polymer, silver vaporized, specular
- Softec lens

2 ERCO LED-module

- High-power LEDs: warm white (2700K or 3000K) or neutral white (3500K or 4000K)

3 Louvre

- Polymer, black lacquered or aluminum vaporized, silver, specular
- Downlight: cut-off angle 30° from horizontal
- Wallwasher: cut-off angle 70° from horizontal

4 Mounting frame

- Covered mounting detail
- Mounting for ceiling thicknesses to max. 1" / 25mm
- Polymer, white
- For flush mounting: mounting frame to be ordered separately, fixing for ceiling thicknesses of 1/2" - 1" / 12.5-25mm

5 Housing

- Aluminum profile, designed as heat sink

6 Control gear

- Trailing edge dimmable or 0-10V dimmable

Trailing edge dimmable version:

- Operation at 120V: Dimming with external dimmers possible
- Operation at 277V: switchable

Variants on request

- Anti-glare louvre: coated matt gold, matt silver or matt champagne
 - Mounting frame: 10,000 further colors
 - Control: Lutron
- Please contact your ERCO consultant.



Design and application:
www.erco.com/compar-linear

Compar linear Recessed luminaires

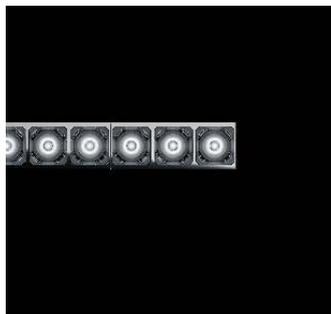

Louvres for efficient visual comfort

A louvre is designed to restrict the view into the luminaire, achieving efficient visual comfort with an emission angle of 90°. An anti-glare louvre available in black or silver enables the luminaire to blend with the material and color of the ceiling.



Suitable for office workstations

ERCO develops luminaires with the specifications of good glare control and high visual comfort. UGR values are used as support for purely norm-referenced lighting. With downlights though this should not be carried out using 'blanket' values, but should be implemented according to the individual arrangement of luminaires in the room.



Covered or flush mounting detail

Compar recessed downlights are supplied with an overlapping mounting detail. Flush mounting details are available as accessories to facilitate site logistics.



Shallow recess depth

In compact installation situations, every millimeter is decisive with the recess depth of a luminaire. ERCO has thus developed special luminaires for shallow recess depths that guarantee very good quality of light even in very tight installation conditions.

Special characteristics	
	Excellent visual comfort
	For office workstation lighting as of UGR 13.4
	Flush or covered mounting detail
	Shallow recess depth



ERCO high-power LEDs



Efficient lens system



Cut-off 30°/70° from horizontal



Different light colors



Excellent thermal management



EMC-optimized



Various construction sizes



Tool-free mounting



Trailing edge dimmable



0-10V dimmable

Compar linear Recessed luminaires – Luminaire arrangement

Downlights

Spot, Flood, Wide flood, Extra wide flood

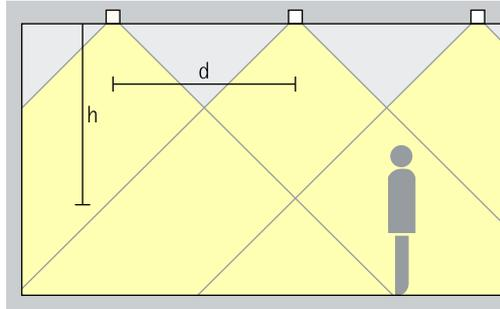

General lighting

For optimum general lighting, the luminaire spacing (d) between two Compar downlights may, as a rough guide, be up to 1.5 times the height (h) of the luminaire above the working plane.

Arrangement: $d \leq 1.5 \times h$

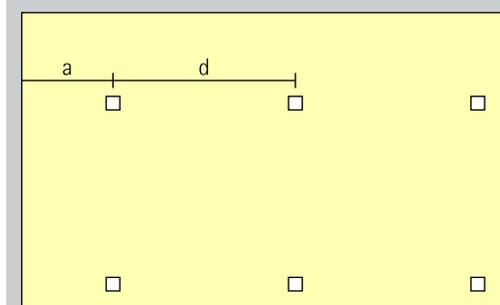

The wall offset should be half the luminaire spacing.

Arrangement: $a = d / 2$

Downlights oval wide flood

Oval wide flood

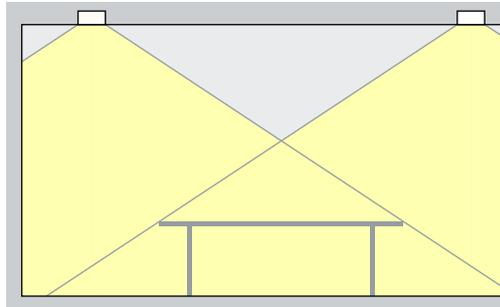

General lighting

For efficient workplace illumination in the office, with optimal uniformity and good facial recognition, the luminaire spacing (d) of Compar downlights with oval wide flood distribution (d) may be up to 1.5 times the height (h) of the luminaire above the working plane.

Arrangement: $d \leq 1.5 \times h$

Downlights oval flood

Oval flood

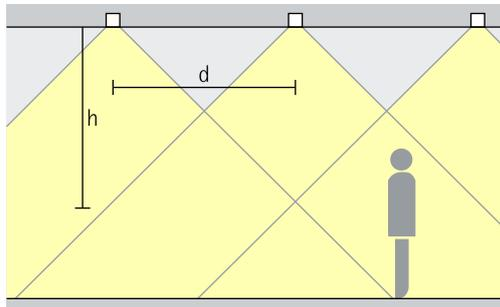

Linear lighting

As a rough guide for uniform illumination, the luminaire spacing (d) between two Compar downlights installed in a row may be up to 1.5 times the height (h) of the luminaire above the working plane.

Arrangement: $d \leq 1.5 \times h$

Application area: Hallways and corridors as well as above tables.

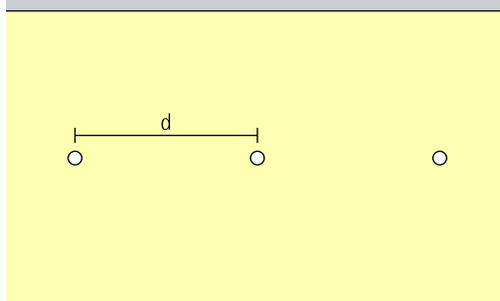

Compar linear Recessed luminaires – Luminaire arrangement

Lens wallwashers
Wallwash

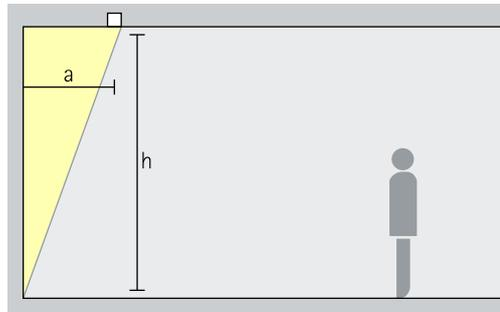

Wallwashing

For uniform vertical illuminance, the distance (a) of Compar lens wallwashers from the wall should be around one third of the wall height (h).

Arrangement: $a = 1/3 \times h$

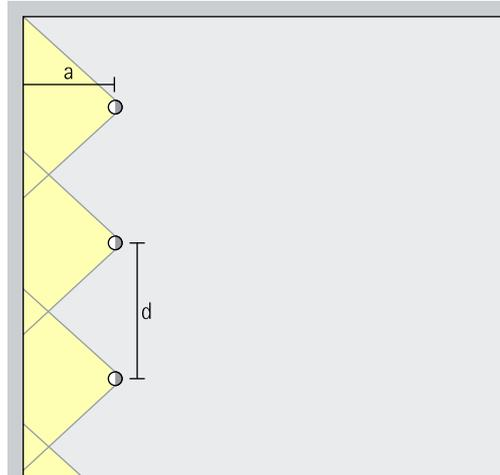

For good longitudinal uniformity, the spacing (d) of Compar lens wallwashers may be up to 1.3 times the offset from the wall (a).

Arrangement: $d \leq 1.3 \times a$

Optimal wall offset and luminaire spacing values are indicated in the wallwasher tables on the product data sheets.

Arup, Sydney.
Lighting design:
Arup. Photogra-
phy: Jackie Chan,
Sydney.



Compar Mounting

Versatile mounting solutions

All Compar recessed luminaires are IC-rated to meet high levels of safety. ERCO offers additional accessories to meet various regional requirements. All recessed luminaires are supplied with control gear and, as tested units, ensure low-maintenance operation. For an elegant ceiling appearance, Compar is also available with flush mounting details.

For mounting details please take a closer look at the installation instructions.

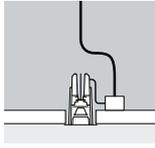

Existing ceiling mounting
With existing flexible conduit, the luminaires may be electrically connected directly to the control gear.

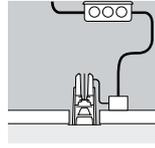

Economical ceiling mounting
For cost effective solution, use of a junction box including flexible conduit for connecting luminaire.

Shallow recess depth
In tight mounting situations, every millimeter counts for the right recess depth of a luminaire. ERCO has therefore developed luminaires with

a shallow recess depth to provide excellent light quality in areas with limited installation space.

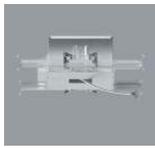
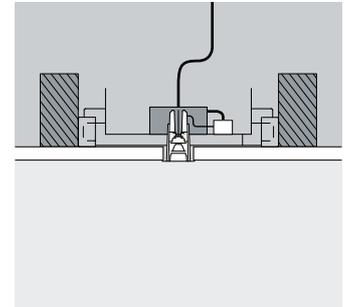
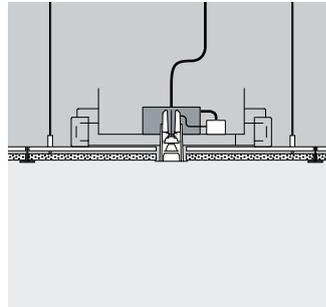
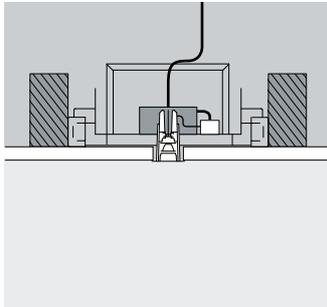

Ultra Airtight housing
An ultra airtight housing with outlet box and flexible conduit for connecting luminaire complete with height adjustable butterfly brackets and universal hanger bars is available to meet local building requirements.

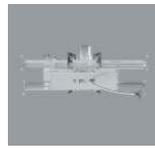

Installation for acoustic ceilings
The plaster frame with junction box and flexible conduit for connecting luminaire supports recessed luminaires in suspended acoustic ceilings.

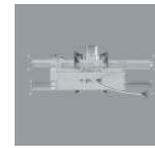

Quick installation
For new construction, the plaster frame, complete with height adjustable butterfly brackets and universal hanger bars allows for very quick mounting.

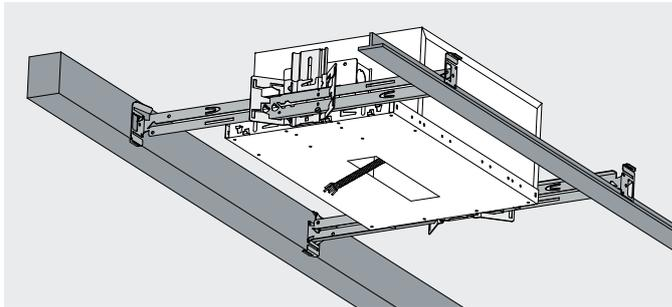

Supplied with universal cross-bars
The universal crossbars works with wood joists and T-Bar construction and offer superior rigidity. They are adjustable from 12-24", with the option to add additional bars for 36-48".

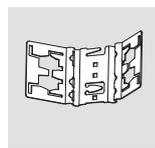

Multi-purpose butterfly bracket
The bracket enables fixtures to be supported with a supplied universal crossbar, as well as furring strip, 1/2" dia. EMT or 1/2", 5/8"-3/4" crossbars. It provides vertical and lateral movement relative to the bar hangers.

Installation detail for flush mounting
A flush mounting plaster frame is available to easily make a clean installation.

Buckford Illumination Group, Melbourne.
Architecture and lighting design:
Buckford Illumination Group.
Photography:
Jackie Chan, Sydney.



Compar linear Recessed luminaires

Construction size

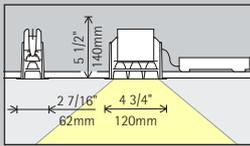

4 3/4"

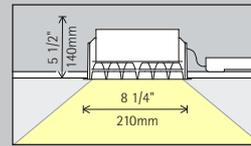

8 1/4"

LED module
Maximum value at 4000K CRI 82

6W/825lm

12W/1650lm

Light color

	2700K CRI 92		3500K CRI 92
	3000K CRI 92		4000K CRI 82
	3000K CRI 97		4000K CRI 92

	2700K CRI 92		3500K CRI 92
	3000K CRI 92		4000K CRI 82
	3000K CRI 97		4000K CRI 92

Light distribution

Downlights	Downlights oval wide flood
Spot	Oval wide flood
Flood	Downlights oval flood
Wide flood	Oval flood
Extra wide flood	Lens wallwashers
	Wallwash

Downlights	Downlights oval wide flood
Spot	Oval wide flood
Flood	Downlights oval flood
Wide flood	Oval flood
Extra wide flood	Lens wallwashers
	Wallwash

Control

	Trailing edge dimmable
0-10V	0-10V

	Trailing edge dimmable
0-10V	0-10V

Color (louvre)

	Silver
	Black

	Silver
	Black

Accessories

	Junction box		Ultra airtight I.C. box
	Flexible metal conduit		Mounting frame
	Plaster frame		

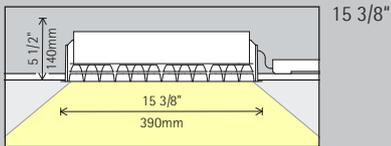

15 3/8"

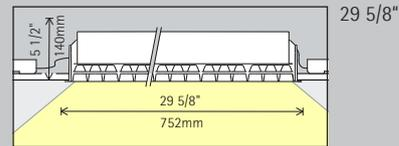

29 5/8"

24W/3300lm

48W/6600lm

	2700K CRI 92		3500K CRI 92
	3000K CRI 92		4000K CRI 82
	3000K CRI 97		4000K CRI 92

	2700K CRI 92		3500K CRI 92
	3000K CRI 92		4000K CRI 82
	3000K CRI 97		4000K CRI 92

Downlights	Downlights oval wide flood
Spot	Oval wide flood
Flood	Downlights oval flood
Wide flood	Oval flood
Extra wide flood	Lens wallwashers
	Wallwash

Downlights	Downlights oval flood
Spot	Oval flood
Flood	Downlights oval wide flood
Wide flood	Oval wide flood
Extra wide flood	

	Trailing edge dimmable
0-10V	0-10V

	Trailing edge dimmable
0-10V	0-10V

	Silver
	Black

	Silver
	Black

Article numbers and planning data:
www.erco.com/016057-us

Design and application:
www.erco.com/compar-linear





Buckford Illumination Group, Melbourne.
Architecture and lighting design: Buckford Illumination Group.
Photography: Jackie Chan, Sydney.

Sede de Colonial en Castellana, Madrid. Lighting design: Maurici Gines, artec3 Studio. Photography: Rafael Vargas.



