



Jilly linear – The versatile light for modern work

An independent design for efficient and ergonomic light in offices

As with the entire Jilly range, Jilly pendant luminaires also specialise in the particularly efficient, standard-compliant lighting of office workplaces. As a pendant luminaire, Jilly offers lighting designers complete freedom to arrange luminaires flexibly and at optimum height in the room. The elegant, flat housing and striking anti-dazzle louvres make Jilly a design statement that stands out from conventional office luminaires. Jilly's lighting technology combines

a highly efficient lens system with an anti-dazzle louvre for visual comfort and luminous efficacy at the same high level. Optionally, an integrated uplight provides diffuse upward light. In the tunable white version, Jilly also supports dynamic lighting concepts which bring the rhythm of daylight into the office.

Jilly linear Pendant luminaires



Structure and characteristics

The features described here are typical of products in this range. Special versions may offer additional or varying features. A comprehensive description of the features of individual products can be found on our website.

1 ERCO lens system

- Made of optical polymer
- Light distributions: extra wide flood or oval wide flood

2 ERCO LED-module

- Mid-power LEDs: warm white (3000K), neutral white (4000K) and tunable white (3000-6000K)

3 Anti-dazzle louvre (light emission below)

- Polymer, black lacquered or aluminium vaporised, silver, mirror-finish

Diffuser (light emission upwards)

- Polymer, textured

4 Housing

- White (RAL9002)
- Aluminium profile/polymer, powder-coated

5 Control gear

- Switchable or DALI dimmable

6 Suspensions

- Wire suspension with 1-point ceiling fixing and rapid wire connector for height compensation
- Ceiling fixture with canopy: metal/polymer, white

Variants on request

- Mid-power LEDs: 2700K, 3000K, 3500K or 4000K with CRI 92
 - Anti-glare louvre: gold matt, silver matt, champagne matt or copper matt-coated and other colours
 - Housing: 10,000 further colours
- Please contact your ERCO consultant.



Design and application:
www.erco.com/jilly-linear-pendant

Jilly linear Pendant luminaires



Tunable white technology

Just as the colour temperature outdoors changes continuously during the day, the colour temperature of indirect lighting can be adjusted indoors to e.g. support lighting concepts for Human Centric Lighting.



Suitable for office workstations

ERCO develops luminaires with the specifications of good glare control and high visual comfort. UGR values are used as support for purely norm-referenced lighting. With downlights though this should not be carried out using 'blanket' values, but should be implemented according to the individual arrangement of luminaires in the room.

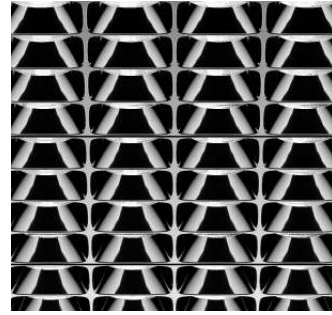

Louvres for efficient visual comfort

A louvre is designed to restrict the view into the luminaire, achieving efficient visual comfort with an emission angle of 90°. An anti-glare louvre available in black or silver enables the luminaire to blend with the material and colour of the ceiling.

Special characteristics

UGR	For office workstation lighting from UGR 13.8
	Tunable white
	Improved visual comfort



ERCO mid-power LEDs



Efficient lens system



Different light colours



Excellent thermal management



EMC-optimised



Switchable



DALI dimmable

Jilly linear Pendant luminaires – Luminaire arrangement

Pendant downlights Extra wide flood

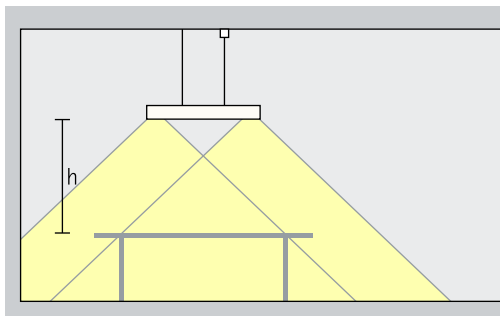

General lighting

To achieve a high level of uniformity and good facial recognition when illuminating single workstations, Jilly pendant luminaires with extra wide flood light distribution should be suspended at a height (h) of approx. 1.2m above the desk plane.

Arrangement: $h = 1,2$

Application area: illumination of desks, counters and conference tables

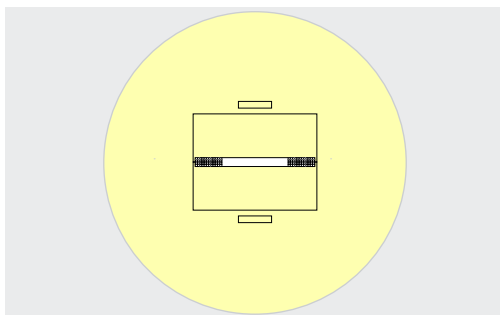

Jilly pendant luminaires with extra wide flood light distribution produce superb uniformity when arranged centrally above the table.

Pendant downlights direct/indirect Extra wide flood

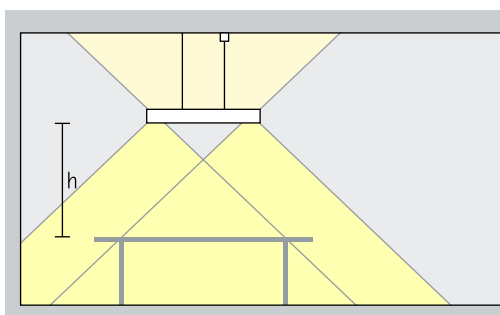

General lighting

To achieve a high level of uniformity and good facial recognition when illuminating single workstations, Jilly pendant luminaires with extra wide flood light distribution should be suspended at a height (h) of approx. 1.2m above the desk plane.

Arrangement: $h = 1,2$

Application area: illumination of desks, counters and conference tables

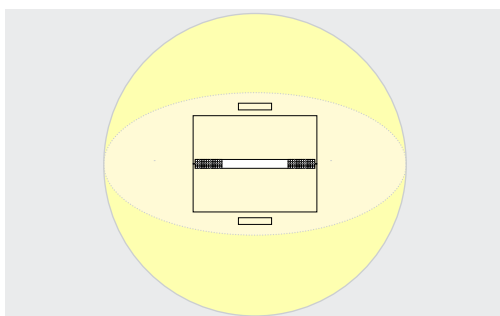

Jilly pendant luminaires with extra wide flood light distribution produce superb uniformity when arranged centrally above the table.

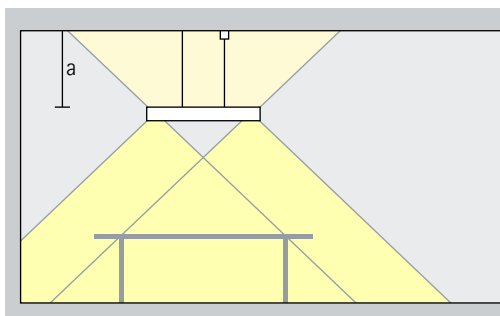

Indirect lighting on bright ceilings increases the visual comfort due to diffusely reflected light. The room also appears to be higher. The luminaire should be suspended from a height of at least 0.5m.

Arrangement: $a \geq 0,5m$

Jilly linear Pendant luminaires – Luminaire arrangement

Pendant downlights oval wide flood
Oval wide flood

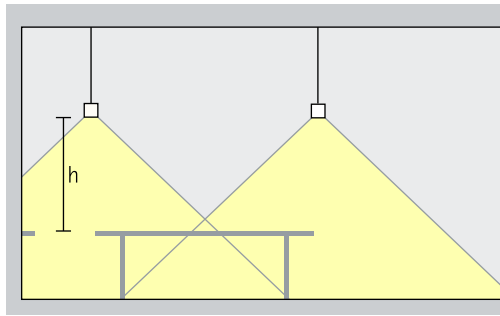

General lighting

To achieve a high level of uniformity and good facial recognition when illuminating single workstations, Jilly pendant luminaires with oval wide flood light distribution should be suspended to the left and right of the desk at a height (h) of approx. 1.2m above the desk plane.

Arrangement: $h = 1,2$

Application area: illumination of desks arranged side by side and wide conference tables.

Pendant downlights oval wide flood direct/indirect
Oval wide flood

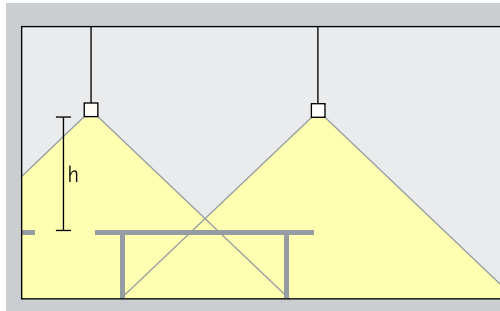

General lighting

To achieve a high level of uniformity and good facial recognition when illuminating single workstations, Jilly pendant luminaires with oval wide flood light distribution should be suspended to the left and right of the desk at a height (h) of approx. 1.2m above the desk plane.

Arrangement: $h = 1,2$

Application area: illumination of desks arranged side by side and wide conference tables.

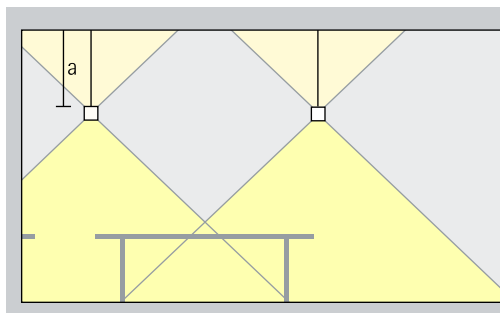

Indirect lighting on bright ceilings increases the visual comfort due to diffusely reflected light. The room also appears to be higher. The luminaire should be suspended from a height of at least 0.5m.

Arrangement: $a \geq 0,5m$

Jilly linear Pendant luminaires

Construction size 1500mm

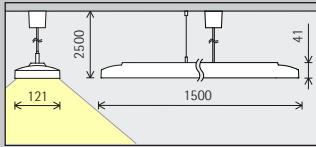

LED module
Maximum value
at 4000K CRI 82

24W/4490lm

Light colour
(direct)

	2700K CRI 92 *		3500K CRI 92 *
	3000K CRI 82		4000K CRI 82
	3000K CRI 92 *		4000K CRI 92 *

Light
distribution

Pendant downlights	Pendant downlights oval wide flood
Extra wide flood	Oval wide flood

Control

	Switchable
	DALI

Colour
(housing/louvre)

	White/Silver		10,000 colours */ Silver
	White/Black		10,000 colours */ Black

Construction size

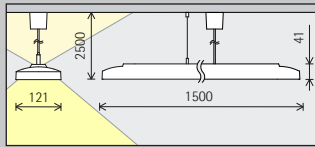

1500mm

LED module
Maximum value
at 4000K CRI 82

39W/7260lm

64W/8640lm

Light colour
(direct)

	2700K CRI 92 *		3500K CRI 92 *
	3000K CRI 82		4000K CRI 82
	3000K CRI 92 *		4000K CRI 92 *

	2700K CRI 92 *		3500K CRI 92 *
	3000K CRI 82		4000K CRI 82
	3000K CRI 92 *		4000K CRI 92 *

Light colour
(indirect)

	2700K CRI 92 *		3500K CRI 92 *
	3000K CRI 82		4000K CRI 82
	3000K CRI 92 *		4000K CRI 92 *

Tunable white

Light
distribution

Pendant downlights	Pendant downlights oval wide flood
Extra wide flood	Oval wide flood

Pendant downlights	Pendant downlights oval wide flood
Extra wide flood	Oval wide flood

Control

	Switchable
	DALI

DALI

Colour
(housing/louvre)

	White/Silver		10,000 colours */ Silver
	White/Black		110,000 colours */ Black

	White/Silver		10,000 colours */ Silver
	White/Black		10,000 colours */ Black

* available on request

Article numbers and planning data:
www.erco.com/017796

Design and application:
www.erco.com/jilly-linear-pendant



