



Compar linear – Linear, with high output and extremely variable

Highly diverse pendant luminaires with linear profiles and direct/indirect illumination

Compar pendant luminaires with their slim design and variable lighting effect are ideal for architectural lighting as well as prestigious offices. The dimensions of the suspended profile are identical to the Hi-trac track. It combines direct and indirect lighting. The innovative lighting technology features various wattages and light distributions for standard-compliant, glare-free lighting in the office workplace. The integrated uplight emits diffuse light upwards. It is

also available in tunable white: for atmospheric, dynamic lighting or concepts that bring the rhythm of daylight into offices.

Compar linear Pendant luminaires



Structure and characteristics

The features described here are typical of products in this range. Special versions may offer additional or varying features. A comprehensive description of the features of individual products can be found on our website.

1 ERCO lens system

- Made of optical polymer
- Light distributions: wide flood, extra wide flood or oval wide flood

2 ERCO LED-module

- High-power LEDs: warm white (2700K or 3000K) or neutral white (3500K or 4000K)
- Mid-power LEDs: Tunable white (3000-6000K)

3 Anti-dazzle louvre (light emission below)

- Polymer, black lacquered or aluminium vaporised, silver, mirror-finish
- Cut-off angle 30°

Diffuser (light emission upwards)

- Polymer, textured

4 Housing

- Aluminium profile, powder-coated

5 Control gear

- Switchable or DALI dimmable

6 Suspensions

- Wire suspension with 1-point ceiling fixing and rapid wire connector for height compensation
- Ceiling fixture with canopy: metal/polymer, white

Variants on request

- Anti-dazzle louvre: coated matt gold, matt silver or matt champagne
 - Housing: 10,000 further colours
- Please contact your ERCO consultant.



Design and application:
www.erco.com/compar-linear-pendant

Compar linear Pendant luminaires





Very high visual comfort
A louvre is designed to restrict the view into the luminaire, achieving efficient visual comfort with an emission angle of 90°. An anti-glare louvre available in black or silver enables the luminaire to blend with the material and colour of the ceiling.









Suitable for office workstations
ERCO develops luminaires with the specifications of good glare control and high visual comfort. UGR values are used as support for purely norm-referenced lighting. With downlights though this should not be carried out using 'blanket' values, but should be implemented according to the individual arrangement of luminaires in the room.





Tunable white technology
Just as the colour temperature outdoors changes continuously during the day, the colour temperature of indirect lighting can be adjusted indoors to e.g. support lighting concepts for Human Centric Lighting.

Special characteristics	
	Excellent visual comfort
	For office workstation lighting from UGR 14.9
	Tunable white

	ERCO high-power LEDs
	Efficient lens system
	Cut-off 30°
	Different light colours

	Excellent thermal management
	EMC-optimised
	Various construction sizes

	Switchable
	DALI dimmable

Compar linear Pendant luminaires – Luminaire arrangement

Pendant downlights
Wide flood, Extra wide flood

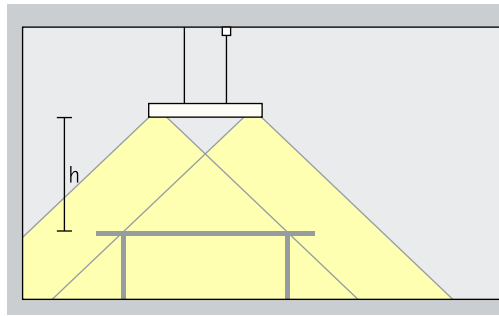

General lighting
To achieve a high level of uniformity and good facial recognition when illuminating single workstations, Compar pendant luminaires with wide flood light distribution should be suspended at a height (h) of approx. 1.2m above the desk plane.

Arrangement: $h = 1.2$

Application area: illumination of desks, counters and conference tables

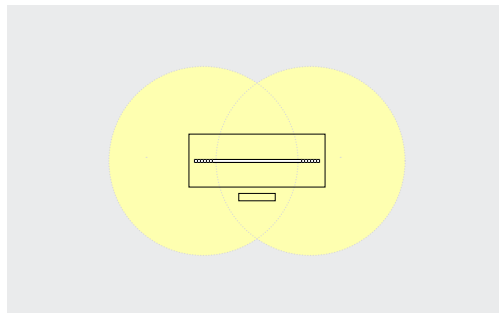

Compar pendant luminaires with wide flood light distribution produce superb uniformity when arranged centrally above the table.

Pendant downlights direct/indirect
Wide flood, Extra wide flood

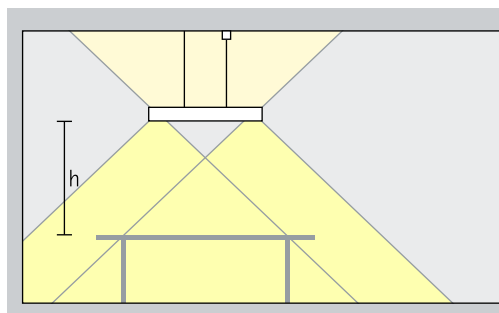

General lighting
To achieve a high level of uniformity and good facial recognition when illuminating single workstations, Compar pendant luminaires with oval wide flood light distribution should be suspended to the left and right of the desk at a height (h) of approx. 1.2m above the desk plane.

Arrangement: $h = 1.2$

Application area: illumination of desks arranged side by side and wide conference tables.

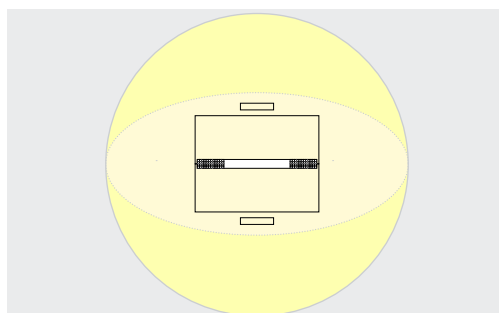

Compar pendant luminaires with wide flood light distribution produce superb uniformity when arranged centrally above the table.

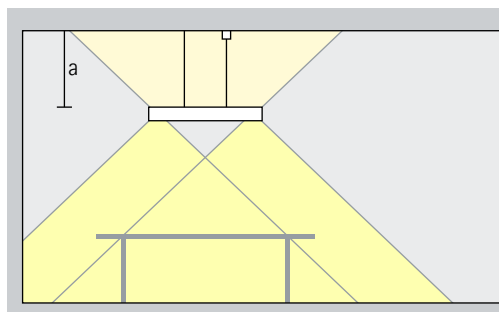

Indirect lighting on bright ceilings increases the visual comfort due to diffusely reflected light. The room also appears to be higher. The luminaire should be suspended from a height of at least 0.5m.

Arrangement: $a \geq 0.5m$

Compar linear Pendant luminaires – Luminaire arrangement

Pendant downlights oval wide flood
Oval wide flood

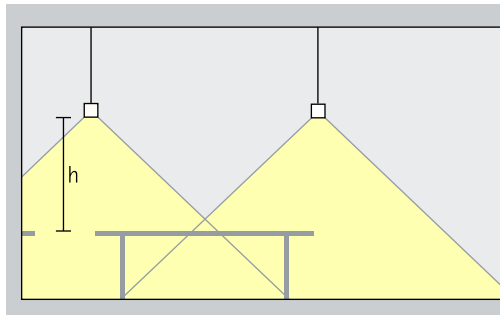

General lighting
To achieve a high level of uniformity and good facial recognition when illuminating single workstations, Compar pendant luminaires with oval wide flood light distribution should be suspended to the left and right of the desk at a height (h) of approx. 1.2m above the desk plane.

Arrangement: $h = 1.2$

Application area: illumination of desks arranged side by side and wide conference tables.

Pendant downlights oval wide flood direct/indirect
Oval wide flood

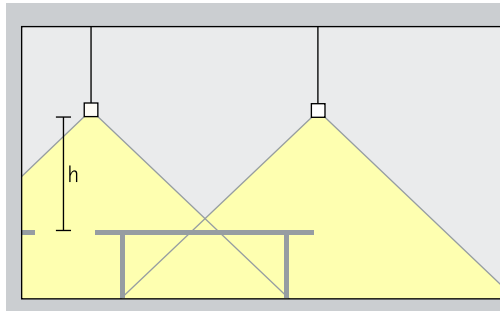

General lighting
To achieve a high level of uniformity and good facial recognition when illuminating single workstations, Compar pendant luminaires with oval wide flood light distribution should be suspended to the left and right of the desk at a height (h) of approx. 1.2m above the desk plane.

Arrangement: $h = 1.2$

Application area: illumination of desks arranged side by side and wide conference tables.

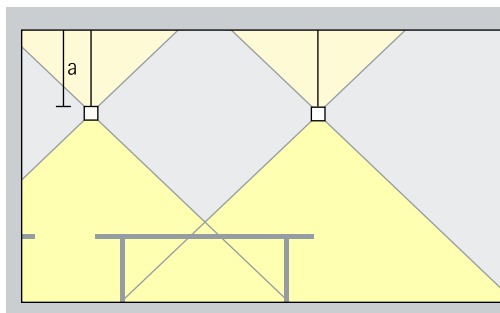

Indirect lighting on bright ceilings increases the visual comfort due to diffusely reflected light. The room also appears to be higher. The luminaire should be suspended from a height of at least 0.5m.

Arrangement: $a \geq 0.5m$

Compar linear Pendant luminaires

Construction size 1200mm

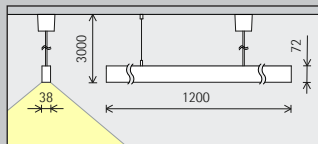

1600mm

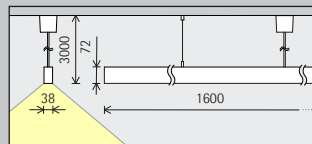

LED module
Maximum value
at 4000K CRI 82

24W/3300lm
38W/4920lm

24W/3300lm
38W/4920lm

Light colour
(direct)

	2700K CRI 92		3500K CRI 92
	3000K CRI 92		4000K CRI 82
	3000K CRI 97		4000K CRI 92

	2700K CRI 92		3500K CRI 92
	3000K CRI 92		4000K CRI 82
	3000K CRI 97		4000K CRI 92

Light
distribution
(direct)

Pendant downlights	Pendant downlights oval wide flood
Wide flood	Oval wide flood
Extra wide flood	

Pendant downlights	Pendant downlights oval wide flood
Wide flood	Oval wide flood
Extra wide flood	

Control

	Switchable
	DALI

	Switchable
	DALI

Colour
(housing/louvre)

	White/Silver		10,000 colours */ Silver
	White/Black		10,000 colours */ Black

	White/Silver		10,000 colours */ Silver
	White/Black		10,000 colours */ Black

Construction size 1200mm

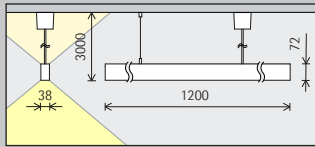

LED module
Maximum value
at 4000K CRI 82

42W/5775lm	64W/7450lm
66W/8610lm	78W/9070lm

Light colour
(direct)

	2700K CRI 92		3500K CRI 92
	3000K CRI 92		4000K CRI 82
	3000K CRI 97		4000K CRI 92

Light colour
(indirect)

	2700K CRI 92		3500K CRI 92
	3000K CRI 92		4000K CRI 82
	3000K CRI 97		4000K CRI 92

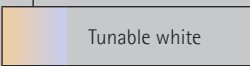

Light
distribution
(direct)

Pendant downlights	Pendant downlights oval wide flood
Wide flood	Oval wide flood
Extra wide flood	

Control

Switchable	DALI
DALI	

Colour
(housing/louvre)

	White/Silver		10,000 colours */ Silver
	White/Black		10,000 colours */ Black

* available on request

Article numbers and planning data:
www.erco.com/016773

Design and application:
www.erco.com/compar-linear-pendant



Compar linear Pendant luminaires

Construction size

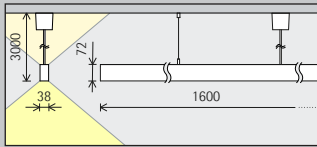

1600mm

LED module
Maximum value at 4000K CRI 82

42W/5775lm
66W/8610lm

64W/7450lm
78W/9070lm

Light colour (direct)

	2700K CRI 92		3500K CRI 92
	3000K CRI 92		4000K CRI 82
	3000K CRI 97		4000K CRI 92

	2700K CRI 92		3500K CRI 92
	3000K CRI 92		4000K CRI 82
	3000K CRI 97		4000K CRI 92

Light colour (indirect)

	2700K CRI 92		3500K CRI 92
	3000K CRI 92		4000K CRI 82
	3000K CRI 97		4000K CRI 92

	Tunable white
--	---------------

Light distribution (direct)

Pendant downlights	Pendant downlights oval wide flood
Wide flood	Oval wide flood
Extra wide flood	

Pendant downlights	Pendant downlights oval wide flood
Wide flood	Oval wide flood
Extra wide flood	

Control

	Switchable
	DALI

	DALI
--	------

Colour (housing/louvre)

	White/Silver		10,000 colours */ Silver
	White/Black		10,000 colours */ Black

	White/Silver		10,000 colours */ Silver
	White/Black		10,000 colours */ Black



* available on request

Article numbers and planning data:
www.erco.com/016773

Design and application:
www.erco.com/compar-linear-pendant





Sede de Colonial en Castellana, Madrid. Lighting design: Maurici Gines, artec3 Studio. Photography: Rafael Vargas.

Fabege AB - WAW
Arena Staden,
Stockholm. Archi-
tecture: ABREU
Design Studio;
EgnellAllard
Inredningsarkitek-
tur, Stockholm.
Lighting design:
ABREU Design
Studio. Electrical
engineering:
Stockholms
Eltjänst Lun-
dén AB; Elbolaget
LMJ AB; Lundek
Elkonsult AB;
Elarkitektur AB.
Photography:
Gavriil Papadiotis,
London.



